

SMART LYO®

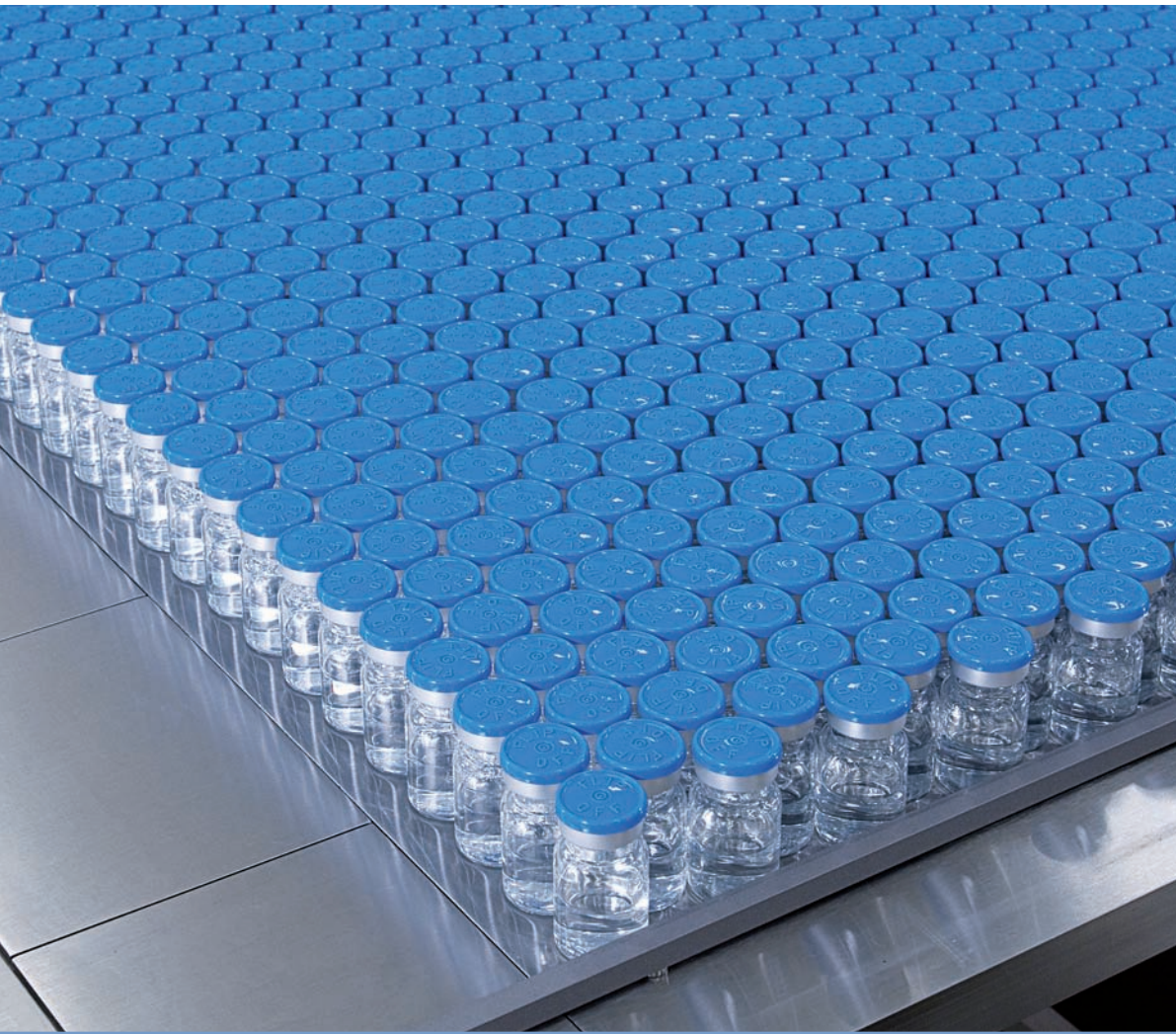

*the SMART way to make Freeze Drying affordable*

GEA Pharma Systems supplies advanced technologies for the processing of Active Pharmaceutical Ingredients (API) for the production of oral and parenteral dosage forms.

GEA Pharma Systems strives for *Price/Performance Leadership* providing its customers with highly cost-effective, integrated systems for the pharmaceutical industry. GEA Pharma Systems is dedicated to innovation and thereby providing durable quality through its well-established brands: *Aeromatic-Fielder™* and *Collette™* - batch and continuous granulation, drying, pelletizing and coating; *Buck®* - contained materials handling; *Courtoy™* - tablet compression; and *Lyophil™* - pharmaceutical freeze drying and automated vial handling systems.

GEA Pharma Systems' activities include partnering with customers to develop new products and enhance clinical effectiveness; the supply of R&D-scale and stand-alone production equipment; and the installation of complete integrated production lines.

## Financial Strength with GEA Group

As an internationally operating technology group the company focuses on process technology and components for demanding production processes in various end markets. GEA Group is a market and technology leader in 90% of its business areas. It has a workforce of over 20,000 serving customers in 50 countries.

# GEA Lyophil

For more than half a century GEA Lyophil has designed and manufactured freeze dryers for the pharmaceutical and biotech industry.

## Leader in Technology

GEA Lyophil supplies a comprehensive range of products and services, comprising laboratory freeze dryers, both pilot scale for R&D and small production batches; industrial freeze dryers; and complete freeze dryer systems. These include Automatic Loading and Unloading Systems (ALUS®); integrated isolators; and CIP-Skids in a complete system with freeze dryer.

- 55 years of experience in lyophilization development, engineering and manufacturing;
- More than 1000 freeze dryers and automated (un)loading systems in production globally;
- Proven reliability for shelf, chamber, slot door and condenser design;
- Innovative technology to avoid sticking stoppers and to minimise footprint and energy usage;
- Innovators of H<sub>2</sub>O<sub>2</sub> sterilisation technology to save cost and cycle times;
- Customer base includes major Pharma companies, Contract Manufacturing Organisations, and Generics manufacturers, demonstrating operational reliability and quality of components and reputation.

## In-depth Technical Understanding

GEA Lyophil uses its proven technology to provide either **standard** or **customised** solutions.

Capacities range from R&D, to stand-alone production plants, to high-capacity systems for bulk APIs, blood plasma, vaccines, hormones, antibiotics/anti-infectives, bacteria, sera, enzymes and diagnostic agents.

Plant configuration extends from specialised solutions for highly potent products to two-storey units and fully integrated systems with multiple freeze dryers and loading systems, with or without the integration of your chosen filling system supplier.



# SMART LYO®

SMART LYO® is a new range of competitively-priced pharmaceutical freeze dryers with advanced technology from GEA Lyophil – a world leader in freeze drying technology.

**Standardised & Customised** - SMART LYO® pharmaceutical freeze dryers are designed from proven standardised modules of the required size to create a plant customised specifically for the needs of each customer. By standardising the technology SMART LYO® reduces costs; makes planning, validation and documentation easier; and significantly reduces delivery times. With SMART LYO® there's no need for compromise: every customer receives exactly the plant they need, when they need it, to suit their existing facilities and production requirements.

**Made in Germany** - German engineering and project control in balance with GEA controlled supply chains make the SMART LYO® freeze dryer a top quality product\*. GEA Lyophil's committed team of engineers and specialists all work to ensure that Lyophil freeze dryers are of a consistently high quality. It is this quality that creates reliable, trouble-free pharmaceutical production and whole life economy.

\* Quality Management System certified to ISO 9001 since 1997.



*German engineering and project control*

**Affordable** - Standardised modules are cost efficient to produce and are more reliable than bespoke systems meaning lower purchase and maintenance costs for the customer. Using prefabricated units also reduces delivery times and validation periods giving customers a clear commercial advantage by allowing products to be launched and brought to market more quickly.



**Reliable** - GEA Lyophil has been providing a trusted service and reliable products, configured to minimise production batch loss for more than 50 years. SMART LYO® freeze dryers are no exception. The modules themselves have been tested extensively. They, together with proven process technology and the specialist knowledge of the GEA Lyophil team, guarantee trouble-free operation for smooth production and minimum downtime. Should a problem occur, the Global Service Network is ready to spring into action immediately by dispatching spare parts or a service engineer to assist staff.

**Technology** - SMART LYO® freeze dryers use only proven technology and can be supplied with filling systems, isolators and full inspection services to provide a completely integrated production facility from a single supplier. Each component meets the highest possible technical requirements and the strict standards of the global licensing authorities as well as complying with all the current guidelines such as GAMP, cGMP, FDA, etc.

SMART LYO® freeze dryers are available in shelf sizes of 0.57 m<sup>2</sup> up to 20 m<sup>2</sup> with a condenser capacity of up to 400kg.

# Options

## Smart Features:

- The entire system is constructed on a single-floor plant frame for fast, simple commissioning. The system includes: the compact chamber/condenser unit, all system modules (hydraulics, venting system, vacuum) and available options such as CIP and SIP.
- It is possible for the refrigeration unit to be installed remotely from the plant frame, even on a different floor if necessary. This allows the installation to be adapted as required to fit the customer's infrastructure.
- The electrical cabinet can be positioned conveniently within the freeze dryer plant or centrally in a control room.
- Frame mounting allows SMART LYO® freeze dryers to be installed within the existing building architecture, i.e. the machinery room and the sterile area. This means that installation and assembly is very simple requiring just the connection of the plant to the unit frame and the switch cabinet.
- The GEA Lyophil Global Service Network provides rapid availability of original manufacturers' spare parts worldwide, with comprehensive service and repair to minimise downtime and keep costs under control.
- Comprehensive documentation explaining both the operation and maintenance of the freeze dryer plant.
- H<sub>2</sub>O<sub>2</sub> sterilisation with VAPOVAC™ steriliser.
- CIP system for cleaning the chamber and condenser.
- SIP system for steam sterilisation of the plant including all the necessary instruments and components as well as the upgrading of the chamber and condenser to one pressure vessel.
- Re-cooling of the freeze-drying chamber including the door, constructed as a jacket for effective and rapid re-cooling of the plant following steam sterilisation.
- FAT (Factory Acceptance Tests) to demonstrate the conformance of installation and key performance of the equipment with the specifications.
- A standardised IQ/OQ package allows rapid validation of the plant.

Model	SL 10 - 80	SL 10 - 80
	No CIP / SIP	CIP / SIP
<b>Chamber</b>	•	•
Rectangular chamber	•	•
Pressure less	•	≠
CIP	≠	•
SIP	≠	•
Material 316 L	•	•
"Surface Ra 0,8 µm "	•	•
Ports 3d	•	•
<b>Door</b>	•	•
Full size door	•	•
automatic locking	≠	≠
<b>Condenser rectangular Single Skid</b>	•	•
Rear	•	•
"Ra<0,8µm "	•	•
<b>CIP</b>	o	•
CIP Chamber + Condenser	≠	•
Lost water	•	•
<b>SIP</b>	≠	•
PED	≠	•
ASME	≠	o
<b>Hydraulic</b>	•	•
Stoppering	o	o
<b>Shelf package</b>	•	•
Bellow	o	•
<b>Refrigeration</b>	•	•
Compressor Bitzer	•	•
<b>Vacuum</b>	•	•
Oil sealed vacuum pump	•	•
<b>Pressure regulation</b>	•	•
on/off	•	•
MKS Flow controller	o	o
<b>Process sensors</b>	•	•
Pirani	•	•
MKS	o	o
<b>Venting System incl. filter</b>	•	•
Sterilisable	≠	•
Ports for I-Test	o	•
<b>Control System and Documentation</b>	•	•
Siemens	•	•
Allen-Bradley	o	o
SCADA - WIN CC	•	•
Recorder	o	o
GAMP	o	•
FAT	o	•
IQ/OQ Documents and Tests	o	•
Material Certificates	o	o

• included o Option ≠ not available

# Types and Sizes

## Model SL10 - SL80

Model	Units	SL 10	SL 20	SL 40	SL 60	SL 80
<b>Shelves</b>						
Shelf area	m <sup>2</sup>	"0,57 / 0,71"	"1,1 / 1,4"	"1,8 / 2,2 "	"2,7 / 3,3"	"4,1 / 5"
No. of Vials (Ø 16mm)	Quantity	"2,390"	"4,741"	"7,994"	"11,894"	"17,851"
No. of Vials (Ø 22mm)	Quantity	"1,247"	"2,474"	"4,186"	"6,228"	"9,379"
No. of Vials (Ø 30mm)	Quantity	658	"1,306"	"2,221"	"3,304"	"4,999"
No. Of Shelves	Quantity	4 / 5	4 / 5	5 / 6	5 / 6	5 / 6
Shelf size	mm	460 x 310	460 x 615	615 x 615	615 x 915	915 x 915
Clearance	mm	120 / 90	120 / 90	120 / 100	120 / 100	130 / 110
Shelf temperature	°C	-55 ... +70	-55 ... +70	-55 ... +70	-55 ... +70	-55 ... +70
<b>Condenser</b>						
Condenser Capacity	kg/24h	10	20	40	60	80
Condenser temperature	°C	-75	-75	-75	-75	-75
<b>Unit Dimensions</b>						
Length (B)	mm	2600	2800	3400	3800	3800
Width (A)	mm	1400	1400	2100	2100	2100
Height	mm	2400	2400	2400	2400	2400
<b>Weights</b>						
Unit	t	1.5	2.5	3	4.5	5.5

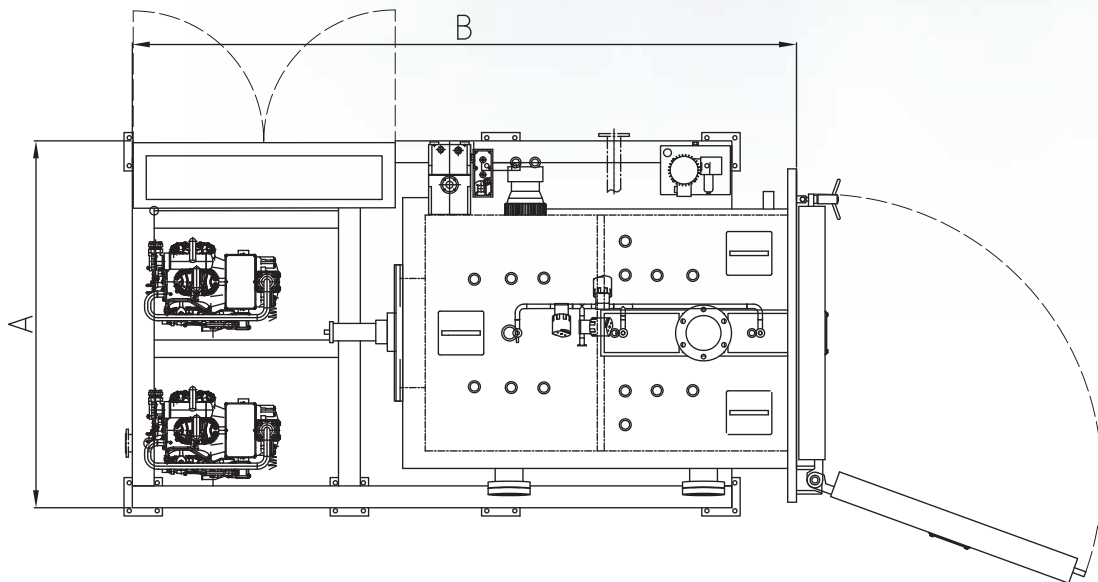

### Technical information

<b>Utilities</b>						
Pure Steam	barg	1.5	1.5	1.5	1.5	1.5
	°C	126	126	126	126	126
CIP Water	barg	3-5	3-5	3-5	3-5	3-5
	°C	80	80	80	80	80
Cooling Water	m <sup>3</sup>	1.5	2	2.5	3	3.5
	°C	< 20	< 20	< 20	< 20	< 20
Electrical Power Supply	m <sup>3</sup> /h (peak)	2.4	5.5	6.5	10.6	10.6
	kW	6	15	21	30	38



# Options

Model	SL 100 - 400	SL 100 - 400
	No SIP	SIP
<b>Chamber</b>	•	•
Rectangular chamber	•	•
Pressure less	•	≠
CIP	○	•
SIP	≠	•
VHP	○	≠
Material 316 L	•	•
"Surface Ra 0,8 µm "	•	•
Ports 3d	•	•
<b>Door</b>	•	•
Full size door	•	•
automatic locking	•	•
Pizza door (constant level loading)	○	○
Door in door	○	○
<b>Condenser rectangular Single Skid</b>	•	•
Rear	•	•
Side	○	○
Bellows	○	•
Perl blasted	•	≠
"Ra<0,8µm "	○	•
<b>CIP</b>	○	•
CIP Chamber + Condenser	•	•
Lost water	•	•
Recirculation	○	○
2 CIP cleaning media	○	○
<b>SIP</b>	≠	•
PED	≠	•
ASME	≠	○
Recooling (Silicone Oil)	≠	○
<b>Hydraulic</b>	•	•
Lift / lower	•	•
Stoppering	○	•
<b>Shelf package</b>	•	•
without rails	•	≠
with rails and fully collapsible	○	•
Bellow	○	•
Interface for ALU	○	○
<b>Refrigeration</b>	•	•
Compressor Bitzer	•	•
Liquid Nitrogen	○	○
Screws	○	○
<b>Vacuum</b>	•	•
Skid (Pump + Blower)	•	•
Redundancy	○	○
Dry Pumps	○	○

• included ○ Option ≠ not available

Model	SL 100 - 400	SL 100 - 400
	No SIP	SIP
<b>Pressure regulation</b>	•	•
on/off	•	≠
MKS Flow controller	○	•
<b>Process sensors</b>	•	•
Pirani	•	≠
MKS	○	•
<b>Venting System incl. filter</b>	•	•
Second venting media	•	•
Sterilisable	≠	•
Ports for I-Test	○	•
Automatic WIT Test	○	○
2 <sup>nd</sup> filter	○	○
<b>Control System and Documentation</b>	•	•
Siemens	•	•
Allen-Bradley	○	○
SCADA - WIN CC	•	•
Wire Numbering	•	•
Recorder	○	○
GAMP	○	•
FAT	○	•
IQ/OQ Documents and Tests	○	•
Welding documentation	○	○
Material Certificates	○	○

• included ○ Option ≠ not available



# Types and Sizes

## Model SL100 - SL400

Model	Units	SL 100	SL 150	SL 200	SL 250	SL 300	SL 350	SL 400
<b>Shelves</b>								
Shelf area	m <sup>2</sup>	5	7.5	10.3	12.3	14.9	17.8	20.4
No. of Vials (Ø 16mm)	Quantity	"21,374"	"32,061"	"42,760"	"52,263"	"63,648"	"76,378"	"87,531"
No. of Vials (Ø 22mm)	Quantity	"11,230"	"16,845"	"22,466"	"27,458"	"33,497"	"40,197"	"46,066"
No. of Vials (Ø 30mm)	Quantity	"5,985"	"8,978"	"11,973"	"14,634"	"17,894"	"21,472"	"24,608"
No. Of Shelves	Quantity	6 + 1	9 + 1	9 + 1	11 + 1	10 + 1	12 + 1	11 + 1
Shelf size	mm	914 x 914	914 x 914	914 x 1219	914 x 1219	1219 x 1219	1219 x 1219	1219 x 1524
Clearance	mm	105	105	105	105	105	105	105
Shelf temperature	°C	-55 ... +70	-55 ... +70	-55 ... +70	-55 ... +70	-55 ... +70	-55 ... +70	-55 ... +70
<b>Condenser</b>								
Condenser Capacity	kg/24h	100	150	200	250	300	350	400
Condenser temperature	°C	-75	-75	-75	-75	-75	-75	-75
<b>Unit Dimensions</b>								
Length (B)	mm	5000	5000	5600	5600	6000	6000	6500
Width (A)	mm	3000	3000	3000	3000	3400	3400	3400
Height	mm	3500	3500	4000	4000	4200	4200	4300
<b>Weights</b>								
Unit	t	7.5	8	9	10	12.5	12.5	15

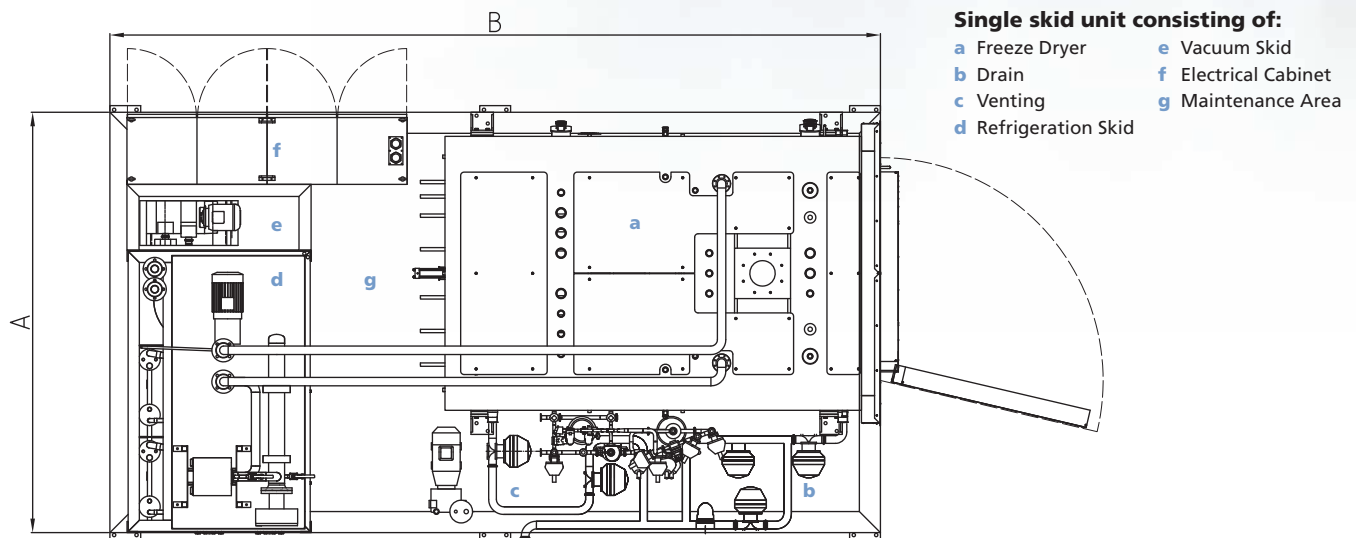

### Technical information

Utilities								
Pure Steam	barg	1.5	1.5	1.5	1.5	1.5	1.5	1.5
	°C	126	126	126	126	126	126	126
CIP Water	barg	3-5	3-5	3-5	3-5	3-5	3-5	3-5
	°C	80	80	80	80	80	80	80
Cooling Water	m <sup>3</sup>	3	4	4.5	5	5.5	6.5	7
	°C	< 20	< 20	< 20	< 20	< 20	< 20	< 20
	m <sup>3</sup> /h (peak)	10.6	10.6	16	16	20	20	30
Electrical Power Supply	kW	33	40	55	65	70	90	105



#### Central Know-How on a Global Scale

Based on a strong commitment to research and development, pharmaceutical technology centres in Belgium, Denmark, Switzerland, the UK, Singapore, and USA provide global technical support and know-how to the pharmaceutical industry. These centres of excellence give customers access to a range of test facilities and expert teams with technical and process know-how. Our teams work closely with our customers to optimise processes and evaluate their products, enabling them to achieve their process and production goals.



#### Contracting Profitable Experience

A world leader in supplying pharmaceutical equipment, GEA Pharma Systems offers manufacturers all over the world the opportunity to enter into a profitable partnership for development and contract. GPS combine advanced in-house technology with a thorough understanding of the pharmaceutical industry to help customers maximize their development results.

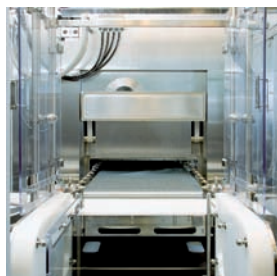

#### Leader in Technology

GEA Lyophil's thorough understanding of the Freeze Drying process enables them to supply a comprehensive range of products and services, comprising laboratory freeze dryers, both pilot scale for R&D and small production batches; industrial freeze dryers; and complete freeze dryer systems. These include Automatic Loading and Unloading Systems (ALUS®); integrated isolators; and CIP-Skids in a complete system with freeze dryer.



© GEA Pharma Systems 2009. Specifications subject to change without notice. All trademarks recognised.

