

Tablet compression
with the PERFORMA™ range

Courtoy PERFORMA™ S with EDD & DS concepts for record-breaking output and productivity

Exchangeable Die Disc (EDD)

The design of the PERFORMA™ S is centred around the EDD: the middle section of the turret, containing the dies, can easily be detached from the upper and lower punch guide parts and handled separately.

The special design of the PERFORMA™ turret makes it possible to either remove the entire turret from the machine, or to just lift and swing the upper section of the turret out of the compression zone, clearing the way for the EDD to be lifted out manually by the operator. The EDD enables fast and easy format change-over, reducing machine downtime, and is a more economical alternative to the conventional exchangeable turret.

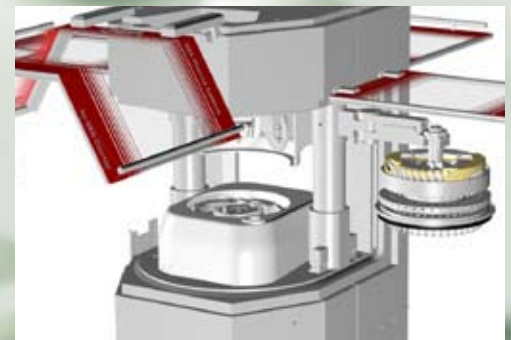
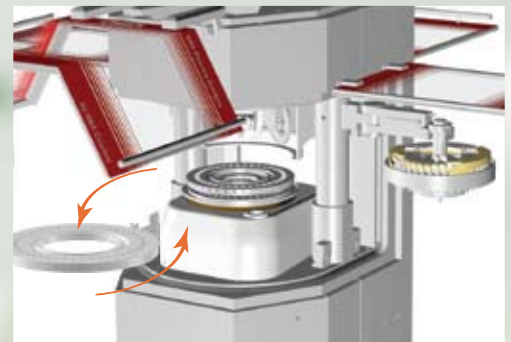

Die Shells (DS)

The PERFORMA™ S is available with conventional dies or Die Shells. Die Shells are dies with very thin walls. Thanks to the reduced total diameter of each die, the number of punch positions on the Die Disc can be increased significantly and machine output can go up by 33%. The minimal thickness of the die walls and the perfect levelling of the Die Shells with the Die Disc surface combine to optimise yield, as there is virtually no powder build-up on the die wall rims. Other benefits of the Die Shells include reduced tooling investment and maintenance cost and minimal risk of tool damage.

Superior Process Control

The PERFORMA™ S features Courtoy's unique tablet weight control system and can be supplied with the optional Dual Control system, which enables monitoring tablet weight and hardness simultaneously, yet independently from one another. These two continuous control loops ensure optimal tablet quality is achieved at all times.

The PERFORMA™ and MODUL™ tablet press range is now available with the novel optional feature "Adjustable dwell time at pre-compression". This functionality allows to increase the dwell time at pre-compression independently from machine speed, resulting in higher machine speeds and more consistent tablet quality.



Courtoy™

Tablet compression
with the PERFORMA™ range

Courtoy PERFORMA™ S SPECIFICATION

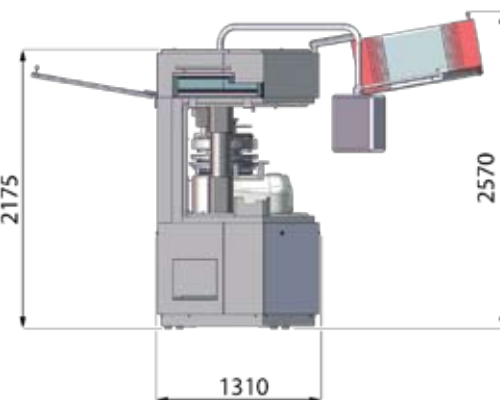
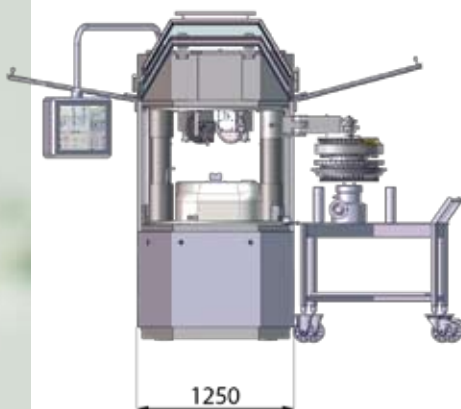
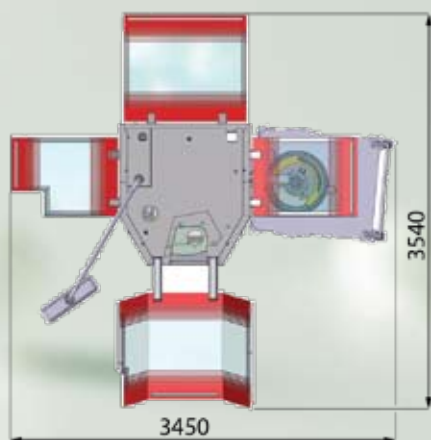

Maximum pre-compression force	10 kN			
Maximum main compression force	100 kN			
Punch type (EUR or TSM)	D	B	BBS	
Top punch penetration [mm]	1 to 4	1 to 4	1 to 4	
Punch body diameter [mm]	25,4	19	16	
Maximum fill depth [mm]	20	19	16	
EDD with conventional dies				
Number of punch positions	31	38	46	52
Die type	D	B	BB	BBS
Maximum tablet diameter / length [mm]	25	16 (L=19)	13 (L=14,3)	8
Output capacity [tab/h]	186000	274000	331000	374000
Die outside diameter [mm]	38,1	30,16	24	22
Die height [mm]	23,81	22,22	22,22	22,22
EDD with die shells				
Number of punch positions	38	46	51*	54
Maximum tablet diameter / length [mm]	25	18 (L=19)	16	12
Output capacity [tab/h]	228000	331000	367000	389000
Die shell outside diameter [mm]	29	22	20	16
Die shell height [mm]	23,81	22,22	22,22	22,22
Machine specifications				
Electrical requirements	3phase+PE – 380V / 400V / 415V / 460V – 50Hz / 60Hz – 14 kVA			
Compressed air requirements	6-8 bar / 100l/m			
Dust extraction requirements	150 m³/h at 15 mbar			
Machine dimensions & weight	W = 1260 mm x D = 1300 mm x H = 2200 mm – 4100 kg			

* Only possible if no upper punch sleeves are selected. This is only possible in case no keys are required on the upper punches (i.e. no shaped tablets and no round tablets with double break-line).



GEA Pharma Systems

www.geapharmasystems.com

GEA Courtoy nv
Bergensesteenweg 186
B-1500 Halle Belgium
Tel: +32 2 363 8300, Fax: +32 2 356 0516
courtoy@geagroup.com