

Tablet Compression - PerFORMa™ P



Courtoy™

With **Exchangeable Die Disc** for conventional dies and **Die Shells**



Productivity – Yield – Flexibility – Quality

GEA Courtoy introduces the PERFORMA™ P with Exchangeable Die Disc for conventional dies and Die Shells.

The PERFORMA™ P is the latest addition to GEA Courtoy's innovative range of rotary tablet presses for the pharmaceutical & nutraceutical industries. The PERFORMA™ P is derived from the well-known MODUL™ P machines and incorporates several new design features (patent pending), offering significant benefits:

1) Increased machine output, offering unmatched productivity.

A larger pitch diameter (compared to machines with a similar footprint), in combination with the novel "Die Shells" instead of conventional dies (optional), results in a large number of punch positions on the turret and consequently a high instantaneous machine output.

While the MODUL™ - based on the ECM concept - is the machine of choice for multi-product and frequent product change-over types of production, the PERFORMA™ range is developed especially for tableting lines where production is characterized by large batches or long campaigns, requiring only few product change-overs.

2) Increased yield

Through a combination of an exclusive new dust extraction system, a feeder with slide-in

wear plate and the innovative "Die Shells", powder losses are reduced to the very minimum.

3) Flexibility in tooling type

The exchangeable turret enables a quick and easy change-over between tooling standards (EU or TSM) and various types (D, B, BB or BBS) of punches and dies.

4) Fast format change-over

The innovative "Exchangeable Die Disc" or "EDD" concept allows exchanging all the punches and dies of the machine in less than 30 minutes - both for round and shaped tablets.

This is possible without duplication of the entire turret - only the EDD needs to be duplicated.

Thanks to the EDD concept, both conventional dies and GEA Courtoy's revolutionary Die Shells can be used on one and the same turret.

5) Superior process control and tablet quality

The PERFORMA™ P is equipped with the same advanced process control features as the MODUL™ tablet presses, such as accurate tablet weight control based on displacement measurement, on-line monitoring of standard deviation in tablet weight, "Dual Control" and "Equal Porosity Tableting".

PerFORMA™ P

- Increased output
- Increased yield
- Flexible tooling change-over
- Fast format change-over
- Low tooling cost
- Superior tablet quality
- Superior process control

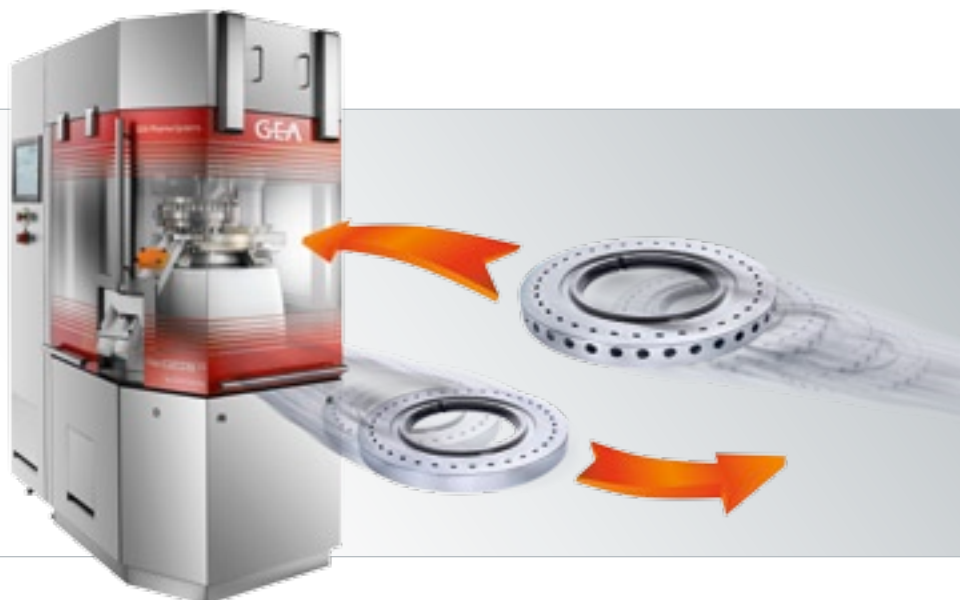

Exchangeable Turret (ET) •

The entire turret, including punches and dies, can be easily removed from the machine and replaced with a duplicate turret in less than 30 minutes.



Benefits of the Exchangeable Turret:

- Enables easy change-over between tooling standards (EU and TSM) and tooling types (D, B, BB and BBS).
- Enables thorough cleaning of the compression area and turret.
- Enables easy access to both the compression area and the turret for inspection and maintenance work.

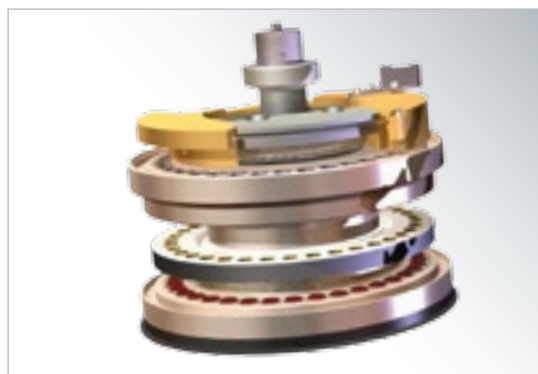

The concept

and Exchangeable Die Disc (EDD - patent pending)

Alternatively, the turret removal arm can be used to lift and swing out the upper punch guide part only. The middle part of the turret, holding the dies, is then easy to remove manually and can quickly be replaced by a duplicate Die Disc. The entire procedure to exchange the EDD takes less than 30 minutes.

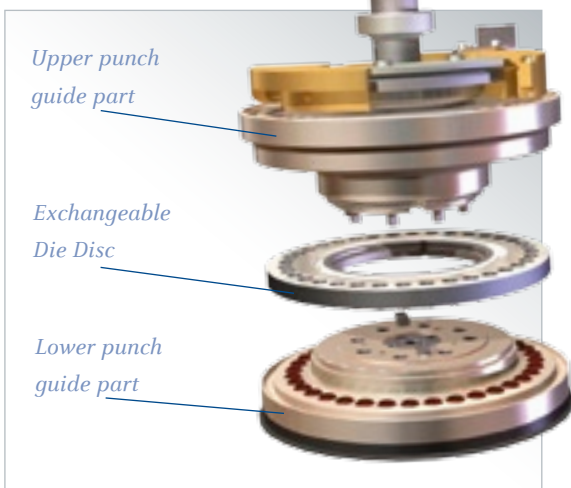
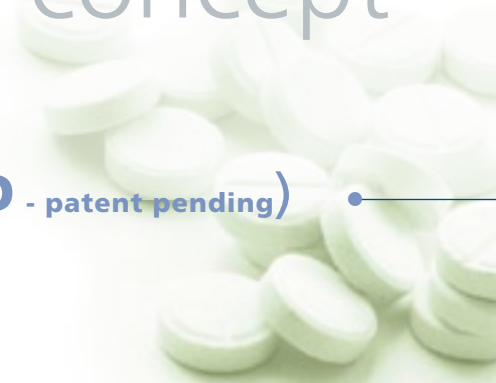

Additional benefits of the Exchangeable Die Disc:

- Fast and easy format change-over: duplicate EDD allows off-line fitting and locking of the dies in the Die Disc.
- More economical alternative to the exchangeable turret: only the Die Disc needs to be duplicated, instead of the entire turret.

Exchangeable Die Disc with conventional dies or Die Shells (DS - patent pending)

EDD cross-section with conventional die and die lock screw

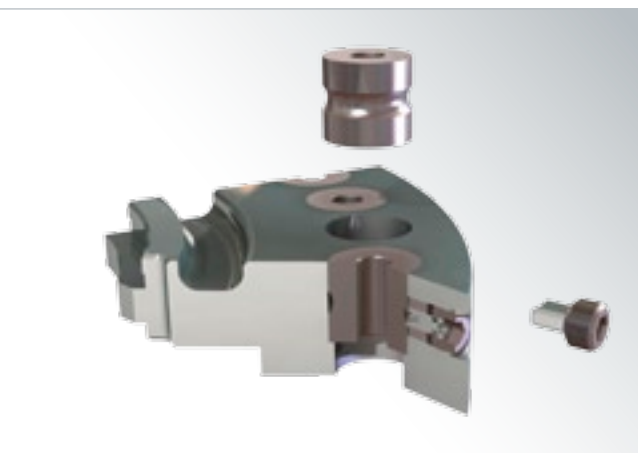

EDD cross-section with Die Shell and clamping system

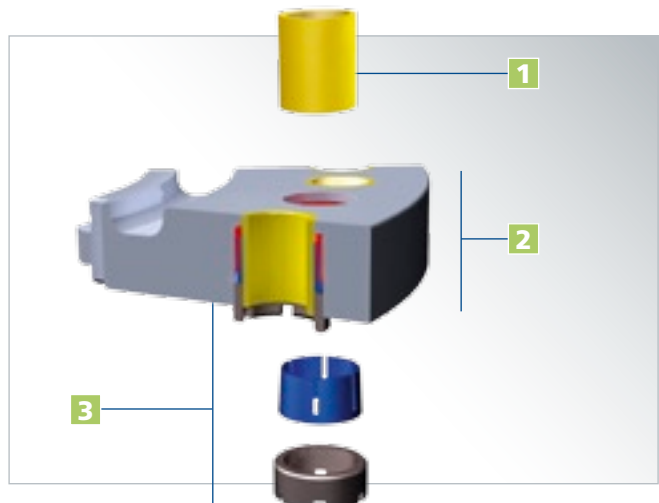

1 The Die Shells have an extremely simple design



2 Dismantling/installation tool for Die Shells



A dedicated tool allows installing the Die Shell level with the die table.

Features:

- The Die Shells have an extremely simple cylindrical shape.
- The Die Shells are available in a variety of materials: standard tooling steel, TuCa, special coated steel and other materials.
- The Die Shells are locked in the Die Disc with a simple conical clamping mechanism.
- The Die Shells are levelled exactly with the Die Disc surface.
- The Die Shells in the EDD are fast and easy to replace, thanks to the use of a dedicated tool.

3 Die Shell clamping device

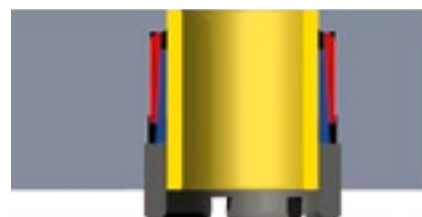

The clamping device clamps the die symmetrically over 360°, preventing even the slightest deformation of the die.



Benefits of the non-segmented Exchangeable Die Disc with replaceable Die Shells:

- Increase in output of up to 50% thanks to the increased number of punch positions on the Die Disc.
- Increased yield thanks to the minimized thickness of the Die Shell walls and the perfect levelling of the Die Shells with the Die Disc surface.
- Reduced tooling investment and maintenance cost thanks to the simple design of the Die Shell.
- Reduced risk of damage to the tooling thanks to the highly accurate and perfectly repeatable positioning of the EDD.
- Low repair cost: if one die opening is damaged, only one Die Shell needs to be replaced.
- Fast product change-over if duplicate or product-dedicated EDDs are used.
- Possibility to optimize the Die Shell material, resulting in reduced ejection forces and consequently a longer life span of the Die Shells.

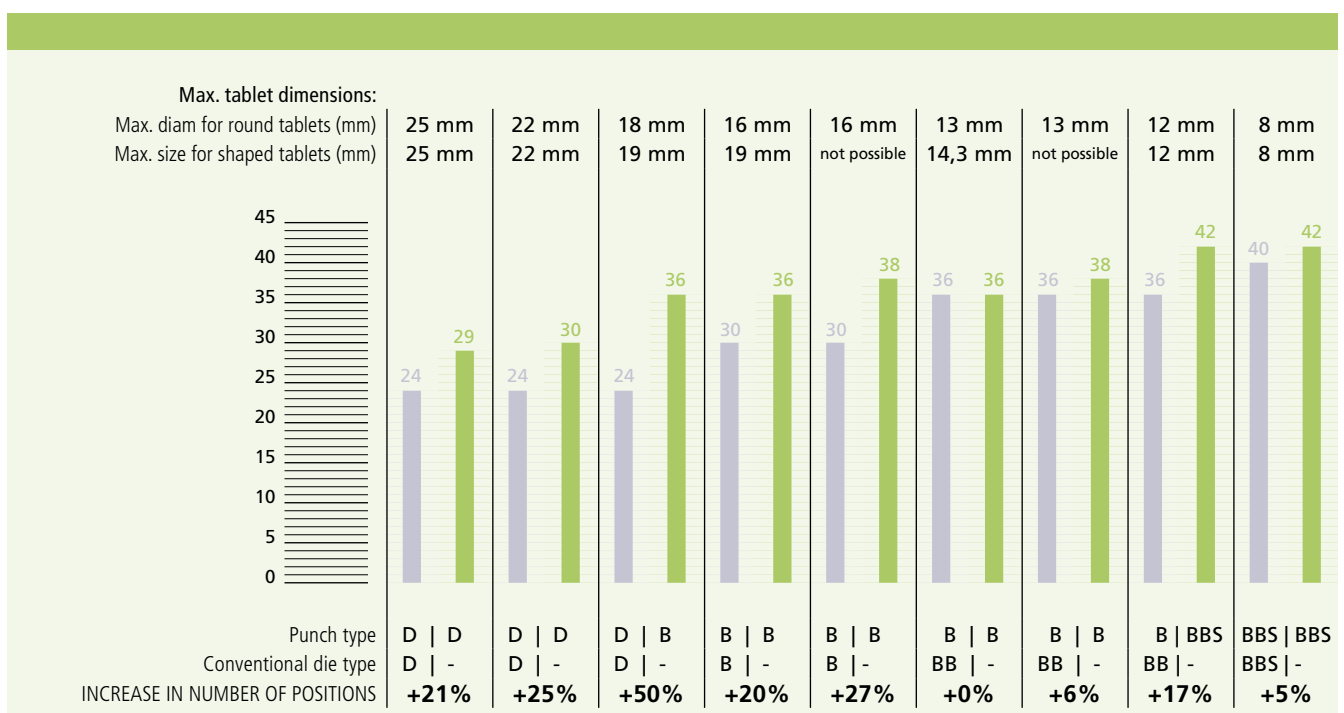
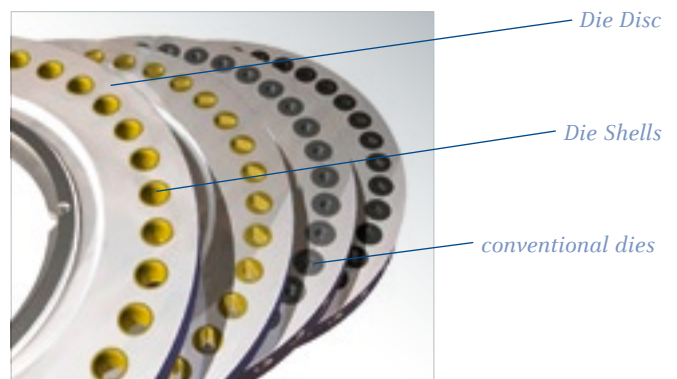

Number of punch positions: ■ conventional dies ■ Die Shells

Courtoy™ specific features and benefits

Extended and freely adjustable dwell time
Benefit: better tablet quality / higher speed

The Courtoy™ air compensator technology offers:

AT PRE-COMPRESSION

- Easy adjustment of dwell time
- More uniform granule distribution within the die
- Better de-aeration of the powder volume
- Harder tablets and/or increased machine speed
- Reduced risk of capping and lamination

AT MAIN COMPRESSION

- Superior punch protection system
- Easy adjustment of dwell time (optional)
- Equal Porosity Tableting (EPT) instead of conventional equal thickness compression (optional)
- Automatic dwell time correction at variable turret speeds (optional)

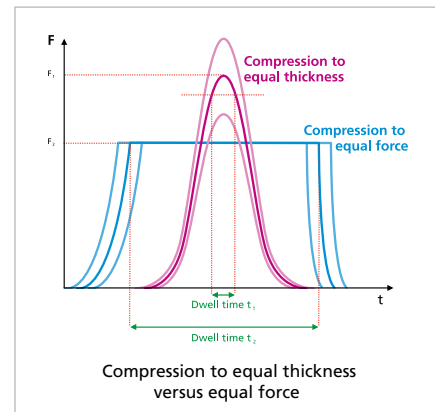
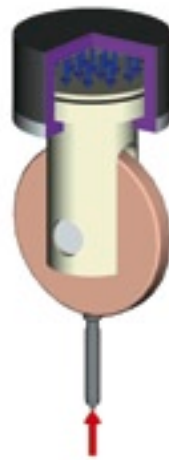

Controlled powder in-feed

Benefit: more uniform tablet weight / higher speed

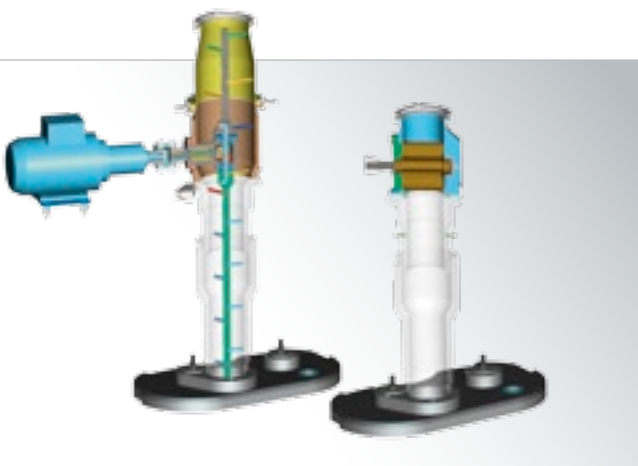

“Agitator” system for poor-flowing powders and “constant level” system for constant powder pressure in the feeder.



The rotary valve of the “constant level” system.

Features

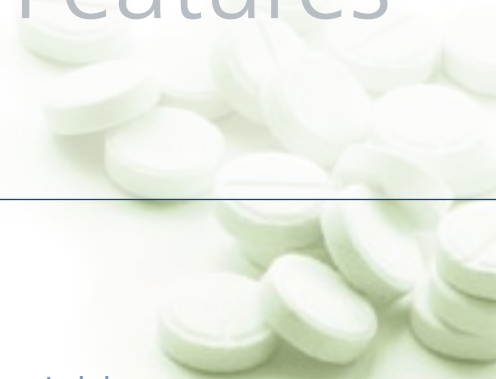

Benefit: higher weight stability / higher speed



Double paddle feeder with 2 independent drive motors.

Benefit: higher yield



Feeder base plate with slide-in wear plate.

Stand-out turret features

Benefit: longer lifetime, lower maintenance cost, easier and faster cleaning

- Forged steel, offering superior strength compared to cast iron (standard)
- Hard chromium coated die table surface (standard)
- Exchangeable top-punch sleeves with key ways (optional)
- Key ways for lower punches (optional)
- Removable plates for punch scraper seals (optional)



Superior process control & tablet quality

Superior process capability for tablet weight

The unique Courtoy™ tablet weight control system is based on the measurement of thickness variations (i.e. “displacement”) under equal force at the pre-compression station. As the relationship between individual displacement values and individual tablet weight is linear, the relative standard deviation (RSD in %) on the displacement is equal to the RSD on the tablet weight.

This enables the control system to monitor and display permanently and on-line the exact process variability with regards to tablet weight. An alarm message - and possible machine stop - can be generated automatically if this standard deviation exceeds a preset tolerance limit. Accurate monitoring, recording and reporting of tablet weight variability enhance overall process capability. This is not possible when tablet weight control is based on the conventional method of measuring the compression force.

Superior process capability for tablet hardness - dual control

When tablet weight control is based on displacement measurement at the precompression station, a separate and independent control loop can be activated on the main compression station. This additional loop guarantees constant average tablet hardness over time by keeping the average compression force constant throughout the batch by automatic adjustment of the distance between the upper and lower main compression rollers.

By eliminating tablet hardness fluctuations over time, machine stops due to IPC (In Process Checks) results being out of specification will be reduced significantly. This in turn contributes greatly to an increase in machine productivity and process yield. Moreover, the hardness control loop will completely eliminate the negative effects of machine warm-up on tablet weight and hardness, which are observed

on many tablet presses. As there are two continuous control loops (one for tablet weight on precompression and one for tablet hardness on main compression) running in parallel but independently of one another, this control principle is called “Dual Control”.

Flexible process control

Although GEA Courtoy strongly recommends using the Dual Control principle to achieve superior process control for both tablet weight and tablet hardness, it is possible to perform tablet weight control based on measurement of the individual compression forces at the main compression station. This makes the Courtoy™ control system very versatile, enabling very easy product transfer.

Equal porosity tableting

“Equal Porosity” tableting is GEA Courtoy’s newest compression principle, which significantly reduces variations in tablet hardness and dissolution time. On conventional tablet presses, irregular filling of the dies and irregular length of the upper and lower punches result in significant variations in individual main compression forces. These force variations lead to important variations in tablet hardness, and consequently tablet porosity and dissolution time. The use of an air compensator on the main compression station allows compressing every tablet to nearly identical porosity, regardless of tablet weight and punch length. As a result, the variability in dissolution time will be significantly lower compared to conventional “equal thickness” tablet compression.

Quality control

The Courtoy™ compression cycle

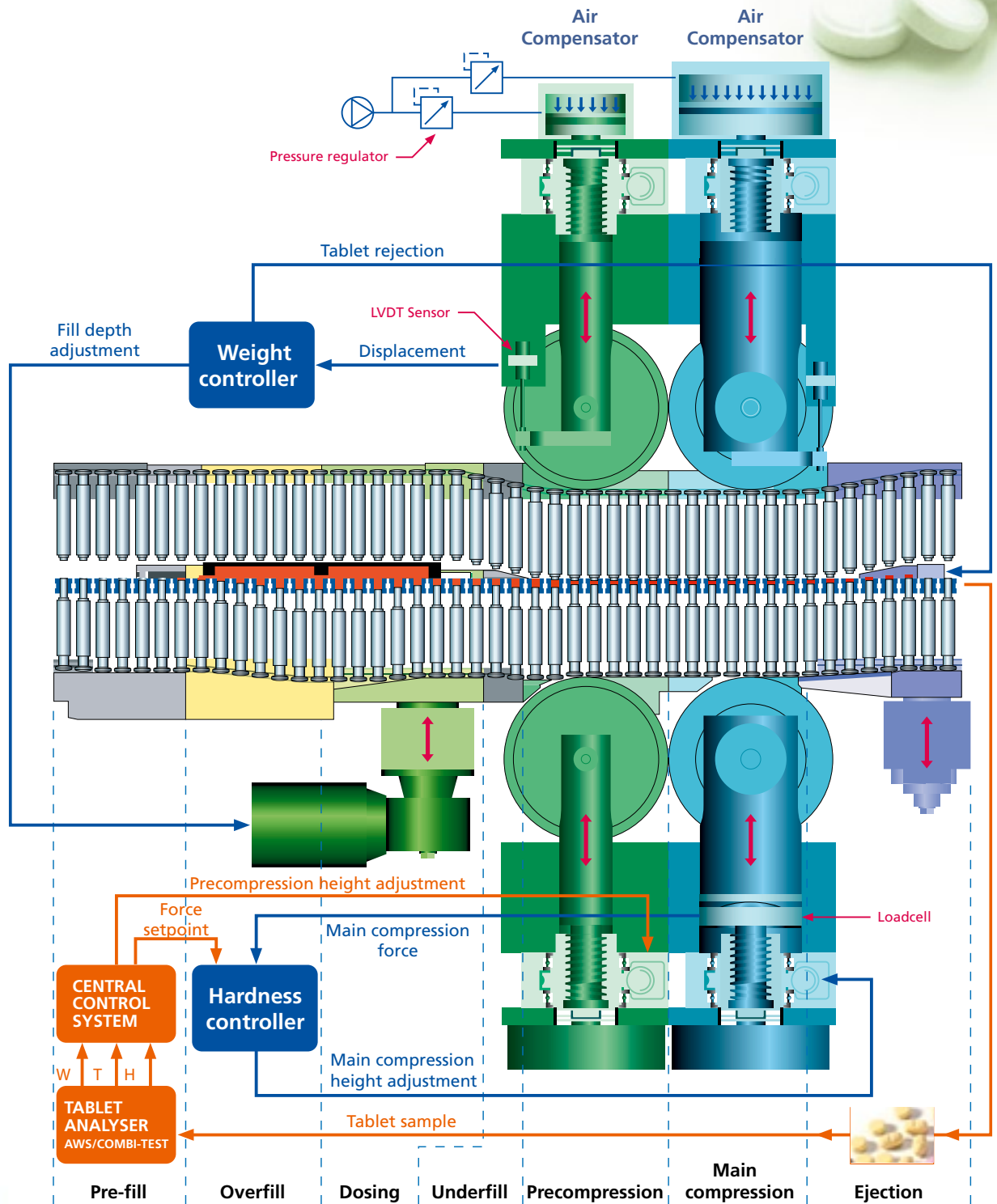

Weight control loop = standard control feature
 Hardness control loop = optional control feature (Dual Control and Dual Reject)
 Tablet analyzer = optional peripheral IPC device

Multi-Control 4

PLC/PC-based



General features:

- Fully automatic system for production and machine control
- Touch-screen based HMI
- Integration of peripheral equipment
- Unlimited number of recipes
- Manual or automatic re-correction of weight control loop
- Modem for remote diagnosis & maintenance
- PC with Windows XP & Win CC
- OPC standard for integration into higher-level management system
- CD-ROM back-up option
- Operator and maintenance manuals as well as mechanical assembly drawings and electrical schematics are fully integrated in the HMI.

Advantages:

- Fully graphical colour HMI is extremely user-friendly
- Statistical batch reporting (distribution and trending graphs)
- 21 CFR Part 11 compliant, including audit trail
- Configurable point verification
- Multi-level user access and password management
- Full data protection

PERFORMA™ specific:

- Turret-exchange procedure is semi-automatic, guiding the operator step by step
- Each operator action is explained with text and visualized with photos
- Each operator action is to be confirmed.
- All sensor off-sets and scalings are entered in specific HMI screen buttons
- Many test and on-line help functions
- Optional Dual Control system for independent monitoring and control of tablet weight and tablet hardness
- Optional Equal Porosity Tableting for reduced variability in tablet hardness and dissolution time

Control cabinet:

- All standard components
- Contains PC and PLC of the MC4 control system, frequency drives etc.
- UPS power supply as standard
- Good accessibility
- Standard cooling unit
- Cable entry with connectors from top or bottom
- Stainless steel housing available as an option
- RAID 5 PC available as an option



Specifications

Technical data and layout

Maximum pre-compression force	10 kN (under extended dwell time)				
Maximum main compression force	80 kN (60 kN in case of Equal Force Compression)				
PUNCH TYPE (EUR OR TSM)	D	B		BBS	
Top punch penetration [mm]	1 to 4	1 to 4		1 to 4	
Punch body diameter [mm]	25,4	19		16	
Maximum fill depth [mm]	20	19		16	
EDD WITH CONVENTIONAL DIES					
Number of punch positions	24	30	36	40	
Die type	D	B	BB	BBS	
Maximum tablet diameter / length [mm]	25	16 (L=19)	13 (L=14,3)	8	
Output capacity [tab/h]	157 000	220 000	264 000	320 000	
Die outside diameter [mm]	38,1	30,16	24	22	
Die height [mm]	23,81	22,22	22,22	22,22	
EDD WITH DIE SHELLS					
Number of punch positions	29	30	36	38*	42
Maximum tablet diameter / length [mm]	25	22	18 (L=19)	16	12
Output capacity [tab/h]	190 000	196 000	264 000	278 700	336 000
Die Shell outside diameter [mm]	30	26	22	20	16
Die Shell height [mm]	23,81	23,81	22,22	22,22	22,22
MACHINE SPECIFICATIONS					
Electrical requirements	3phase+PE – 380 V / 400 V / 415 V / 460 V – 50 Hz / 60 Hz – 7 kVA				
Compressed air requirements	6-8 bar / 100 l/m				
Dust extraction requirements	150 m ³ /h at 15 mbar				
Machine dimensions & weight	W = 1030 mm x D = 1555 mm x H = 2170 mm – 2500 kg				

* Only possible if no upper punch sleeves are selected. This is only possible in case no keys are required on the upper punches (i.e. no shaped tablets and no round tablets with double break-line).

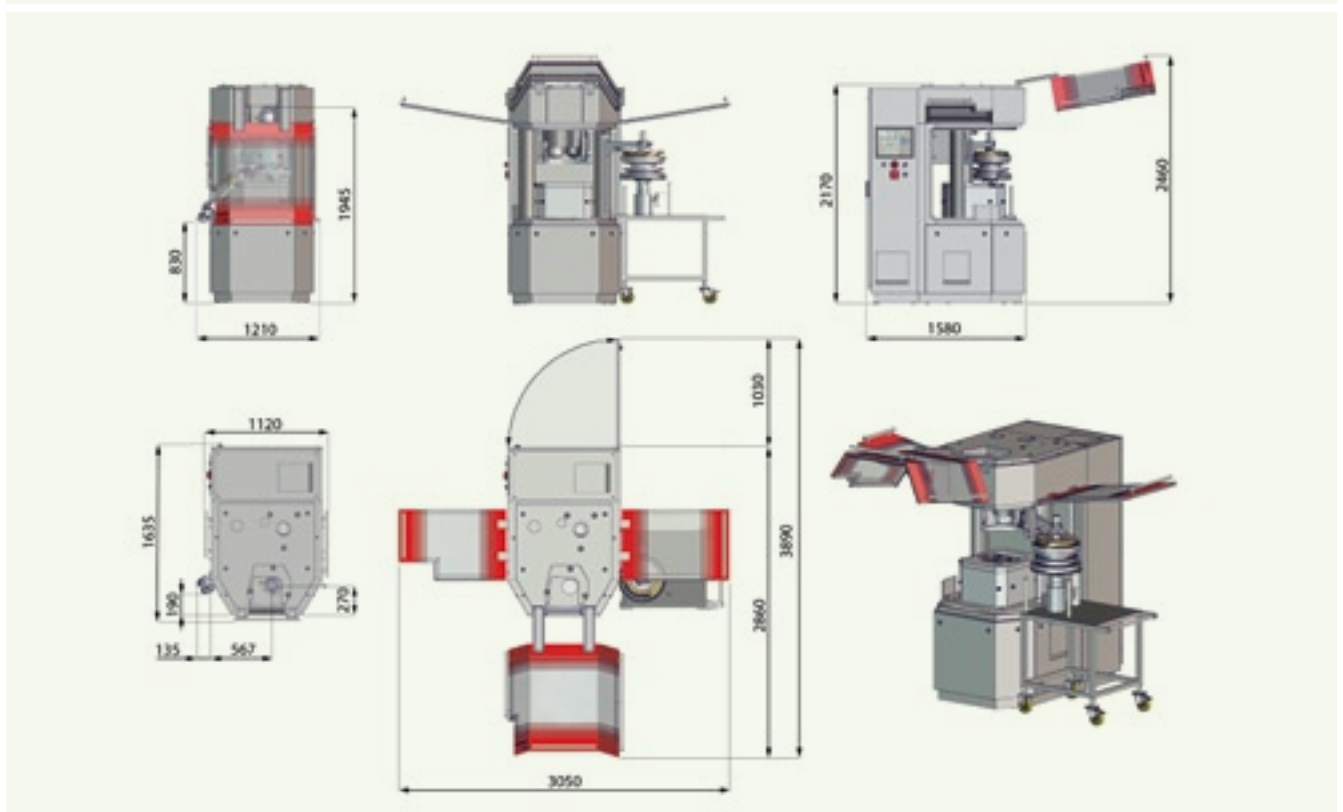

Choose the right Courtoy™ tablet press to meet your specific needs

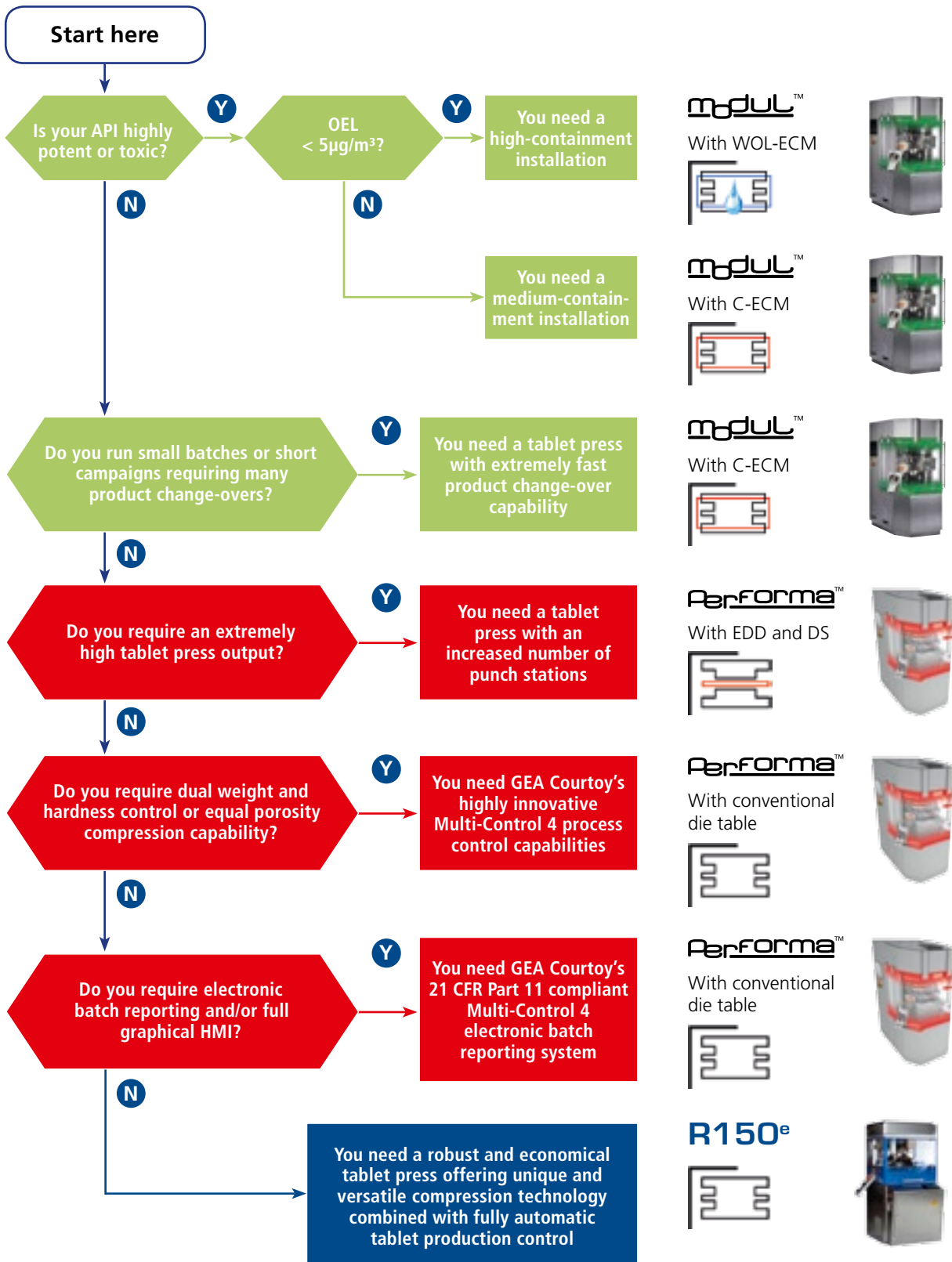

- ECM Exchangeable Compression Module, unique to the GEA Courtoy MODUL™ tablet press. Turret and all product contact and format parts in the same easy-to-remove contained (C) module.
- WOL Wash Off Line. An industry standard aiming at maximizing the equipment's up-time by performing the washing away from the equipment. This concept also allows for toxic materials handling.
- ET or EDT Exchangeable Turret or Exchangeable Die Table. A proven technology that has been available since the early 1990's, offering great tooling flexibility but only a limited time saving during product change-over.
- EDD Exchangeable Die Disc. A new technology introduced by GEA Courtoy on the PERFORMA™ range of machines that allows for extremely fast format change-over.
- DS Die Shells. A thin-wall die for increased productivity through increased number of stations on the turret. Available in conjunction with the Exchangeable Die Disc.

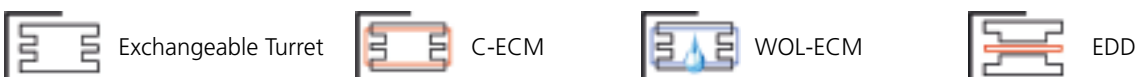

Courtoy™ Technology: Benefits Matrix

	MODUL™ P / S / D	PERFOR- MA™ P	R150 ^e	Increased machine speed & productivity	Increased tablet quality	Increased yield	Increased reliability & maintain- ability
EXCHANGEABLE COMPRESSION MODULE / TURRET / DIE DISC							
Exchangeable Die Table / Turret	≠	●	●	■ ■ ■			■ ■ ■
Exchangeable Die Disc	≠	●	≠	■ ■ ■			■ ■ ■
Die Shells	≠	●	≠	■ ■ ■		■ ■ ■	■ ■ ■
Exchangeable Compression Module	●	≠	≠	■ ■ ■		■ ■ ■	■ ■ ■
Contained ECM (C-ECM)	●	≠	≠	■ ■ ■		■ ■ ■	■ ■ ■
High-Contained ECM (HC-ECM)	●	≠	≠	■ ■ ■		■ ■ ■	■ ■ ■
Wash-Off-Line ECM (WOL-ECM)	●	≠	≠	■ ■ ■		■ ■ ■	■ ■ ■
Bi-layer ECM (B-ECM) on MODUL™ P only	●	≠	≠	■ ■ ■		■ ■ ■	■ ■ ■
Bi-layer kit on MODUL™ D only	●	≠	≠				
Galenic ECM (G-ECM)	●	≠	≠			■ ■ ■	
PERIPHERAL DEVICES FOR TABLET HANDLING							
Standard design	●	●	●				
Dust-tight	●	●	●	■ ■ ■			
Wash-Off-Line	●	≠	≠	■ ■ ■			
Trough-The-Wall technology with open devices	●	●	●	■ ■ ■			
ECM/TURRET/DIE DISC REMOVAL/INSTALLATION							
Removal time (minutes)	10/15/20	15	20	■ ■ ■			
Installation time (minutes)	10/15/20	15	20	■ ■ ■			
Total numbers of parts to be removed/installed on the press	2/2/3	10	10	■ ■ ■			
COMPRESSION DWELL TIME							
Large compression rollers for long dwell time	●	●	●	■ ■ ■	■ ■ ■		
Extended & free adjustable dwell time at pre-compression (PC)	●	●	●	■ ■ ■	■ ■ ■		
Extended & free adjustable dwell time at main compression (MC)	●	●	≠	■ ■ ■	■ ■ ■		
PRODUCTION CONTROL							
Weight control by measurement of displacement at pre-compression	●	●	●		■ ■ ■		
Weight control by measurement of compression force at main compr.	●	●	●		■ ■ ■		
Independent tablet Weight and Hardness control (Dual Control system)	●	●	≠		■ ■ ■	■ ■ ■	
Rejection of tablets outside Weight tolerance limits	●	●	●		■ ■ ■		
Rejection of tablets outside Hardness tolerance limits (Dual Reject system)	●	●	≠		■ ■ ■		
PAT enabling tablet Weight control system	●	●	●		■ ■ ■		
Single reject of tablets	●	●	≠			■ ■ ■	
Tablet sampling gate	●	●	●		■ ■ ■		
COMPRESSION OPERATION PRINCIPLE							
Compression to equal thickness	●	●	●		■ ■ ■		
Compression to equal porosity	●	●	≠		■ ■ ■		
POWDER IN-FEED SYSTEM							
Double-paddle forced feeder with reduced volume	●	●	●			■ ■ ■	
Independent speed adjustment of forced feeder paddles	●	●	●	■ ■ ■	■ ■ ■	■ ■ ■	
Automatic regulation of constant powder pressure inside the feeder	●	●	●	■ ■ ■	■ ■ ■	■ ■ ■	
Anti-bridging agitator system	●	●	●	■ ■ ■	■ ■ ■	■ ■ ■	
Closed feeder with "slide in" wear plate	●	●	●			■ ■ ■	
DUST EXTRACTION SYSTEM							
Manual underpressure regulation	●	●	●			■ ■ ■	■ ■ ■
Underpressure monitoring and alarm	●	●	●			■ ■ ■	■ ■ ■
Automatic underpressure regulation	●	●	●			■ ■ ■	■ ■ ■
PUNCH PROTECTION SYSTEM							
Acts independent from control system = safer than electromechanical system	●	●	●				■ ■ ■
Air cushion based system = safer & cleaner than hydraulic system	●	●	●				■ ■ ■
Punch tightness detection system for upper and lower punches	●	●	●				■ ■ ■
OTHER FEATURES							
Forged steel turret & die table	●	●	●				■ ■ ■
Hard chromium coated die table surface	●	●	●				■ ■ ■
Exchangeable top punch sleeves and upper & lower keyways	●	●	●				■ ■ ■
Removable segmented plates for dies & punch scraper seals	●	●	●	■ ■ ■			
Independent lubrication circuits for upper & lower punches	●	●	●				■ ■ ■
Thermally decoupled drive	●	●	≠		■ ■ ■		
Bad punch detection	●	●	●		■ ■ ■		■ ■ ■
Tablet jamming detection on tablet chute	●	●	●			■ ■ ■	■ ■ ■

● Standard feature ● Option ≠ Not available



Central know-how on a global scale

Based on a strong commitment to research and development, pharmaceutical technology centres in Belgium, Denmark, Switzerland, the UK, Singapore, and USA provide global technical support and know-how to the pharmaceutical industry.

These centres of excellence give customers

access to a range of test facilities and expert teams with technical and process know-how. Our teams work closely with our customers to optimise processes and evaluate their products, enabling them to achieve their process and production goals.



Contracting profitable experience

A world leader in supplying pharmaceutical equipment, GEA Pharma Systems offers manufacturers all over the world the opportunity to enter into a profitable partnership for development and contract. GPS combine advanced in-house technology with a thorough

understanding of the pharmaceutical industry to help customers maximize their development results.

© GEA Pharma Systems 2009. Specifications subject to change without notice. All trademarks recognized. PERFORMA™ patent pending. All copyrights reserved. Under no circumstances should this document or any part of it be copied without GPS' written consent.



GEA Pharma Systems

GEA Courtoy nv

Bergensesteenweg 186

B-1500 Halle · Belgium

Tel: +32 2 363 8300 · Fax: +32 2 356 0516

E-mail: courtoy@geagroup.com