



Central Know-How on a Global Scale

Based on a strong commitment to research and development, pharmaceutical technology centres in Belgium, Denmark, Switzerland, the UK, Singapore, and USA provide global technical support and know-how to the pharmaceutical industry. These centres

of excellence give customers access to a range of test facilities and expert teams with technical and process know-how. Our teams work closely with our customers to optimise processes and evaluate their products, enabling them to achieve their process and production goals.



Contracting Profitable Experience

A world leader in supplying pharmaceutical equipment, GEA Pharma Systems offers manufacturers all over the world the opportunity to enter into a profitable partnership for development and contract. GPS combine advanced in-house technology with a thorough

understanding of the pharmaceutical industry to help customers maximize their development results.



© GEA Pharma Systems 2008. Specifications subject to change without notice. All trademarks recognized.



GEA Pharma Systems

Buck Systems

GEA Pharma Systems Ltd

Wharfdale House, 257 Wharfdale Road

Tyseley, Birmingham, B11 2DP, United Kingdom

Tel: +44 121 765 5800, Fax: +44 121 765 5801

buck.systems@geapharmasystems.com

Blending Technology



Buck Systems Technologies

GEA Pharma Systems is world leader in providing advanced processing solutions for solid dosage forms to the pharmaceutical industry. Based on a dedication to research and durable quality, GEA Pharma Systems offers a wide range of solutions, from individual pieces of equipment to complete integrated plants, by uniting the state-of-the-art technologies of Aeromatic, Buck, Collette, Courtoy, Fielder, Lyophil, Nica and Niro.

Technology

Container blending has long been established as the most efficient method of blending granules and powders in the pharmaceutical manufacturing process. Reduced loading and unloading times, reduced cleaning time of both machinery and room, improved containment and batch integrity have established IBC blending as the pharmaceutical industry's technology of choice.

Efficient Blending Process

Buck Systems have spent years researching and understanding the science of IBC Blending. Homogenous product blending is ensured through scientific design of the blending cage and the container geometry.

The unique Prism™ technology is proven to improve blending times. The additional shear that the Prism™ provides to the mixing process allows even cohesive poor flowing materials to be blended within the IBC.

Long working Life

A robust mechanical construction ensures a long working life for the Buck Blender.

The clamping cage securely clamps at both the top and the bottom of the IBC, which means that no stress from the rotation is exerted on the IBC, preventing premature damage of the IBC's.

Safety First

Air driven screw jacks ensure that the IBC remains clamped in the cage, even when utilities to the machine are lost. Positive IBC detection prevents blender operation unless the IBC is fully clamped. The cage rotation motor is a braked motor, preventing any movement of the cage if utilities are lost, and allowing for Emergency stop of the rotating cage.



Controls

The control system is simple and user friendly, with blend recipes easily loaded and completed batch information printed in an easy to read format. CFR 21 Part 11 compliant controls are available for electronic records and batch information. Blending speed is controlled through a variable speed drive. The control system is available in either Siemens or Allen Bradley versions.

Through the Wall Design

The Pedestal Blender can be designed for installation with the main pedestal housed in a technical area and the clamping cage in the process area. An airtight wall plate is supplied as a barrier between the two rooms. The advantage of this installation is the processing room can be reduced in size thereby reducing room cost and running cost. Technicians can access the pedestal from the technical side, without needing to go through the GMP production area.

Swinging Arms

The Swinging Arms feature allows a wider range of IBC volumes to be handled within the same blender. When a smaller IBC is loaded into the blender, the spacer arms are swung out into the path of the IBC, bridging the height

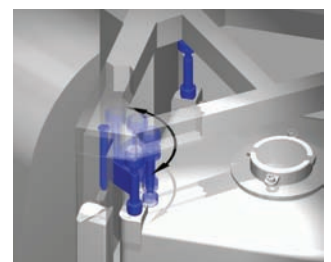

Swinging arms

difference of the smaller IBC. The spacer arms maintain the smaller IBC's position at the centre of the rotation axis, and reduce the clamping time.

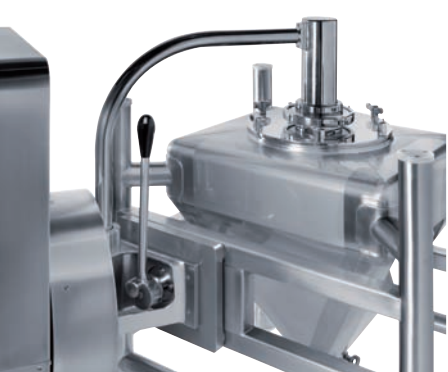

PHB300 with NIR

IBC Blending Technology

Prism™ Mixing

The Prism™ has been developed to aid and improve blending of powdered and granular materials. The Prism™ adds low shear mixing to the rotating IBC, adding to the turbulence of the tumbling product and improving the time to homogeneously blend products.

When the IBC is loaded into the blender, the Prism™ is orientated at right angles to the rotation axis. As the IBC is rotated, the product is divided up by the Prism™, and product is forced outwards to the corners of the IBC.

The Prism™ is of particular benefit to dry blend processes, where IBC Blending is the key process step.



Blender Prism™ integral to the IBC construction

For Dry Blending, or Direct Compression products, the powders are more cohesive and have poorer flow properties. Dry powders take noticeably longer to blend in comparison to free flowing granular materials (for example the dispersion of magnesium stearate into a granulated batch) which blend easily and within a relatively short period of time.

The Prism™ is fully welded into the container body, and can be fully cleaned in place with the Buck Systems' Wash Station.

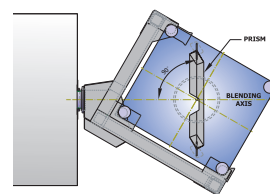

Prism™ mixing

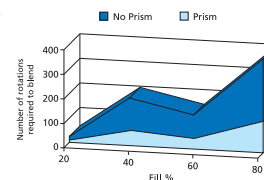

Blending with Prism™ / without Prism™

Process Analytical Technology (PAT) for IBC Blending

All of the Blenders available from Buck Systems can be fitted with Process Analytical Technologies such as Light Induced Florescence (LIF) or Near-Infrared (NIR) systems.

Buck Systems use these technologies on its Blenders to allow the measurement of actual particle movement and conditions in real time as the IBC is blended.

In the laboratory, the technology allows a better understanding of powder behaviour, improving the research and development times and enhancing the process through closer control.

In the production environment, the PAT allows quicker validation of new products, improved productivity and superior containment. By having the results of the completed blend available at the end of the process, the batch can go immediately to the next process, without the need to take samples and analyse the results, saving time and money. The containment of the system is greatly improved because sampling, a task that directly exposes the operator to the product, can be avoided.

Enhanced Design

The technology works by using a measuring head – using either NIR or LIF – mounted onto the rotating blending head which views into the IBC via a viewing window mounted on the wall of the IBC. An onboard data analyser interprets the data from the IBC, and sends the data back to the PC, which has sophisticated software to allow users to monitor the powder movement and to confirm that the product has arrived at a homogeneous blend. Buck Systems have successfully integrated all of this instrumentation onto a rotating assembly within GMP enclosures.

Power is supplied to the instrumentation through a specially designed slip ring, which means the instruments have a permanent and uninterrupted power source. Proximity switches discretely located in the blending head activate the measuring head at precisely the right time to trigger the data acquisition.



Measuring head and data analysing equipment discretely mounted onto the rotating blending head assembly.

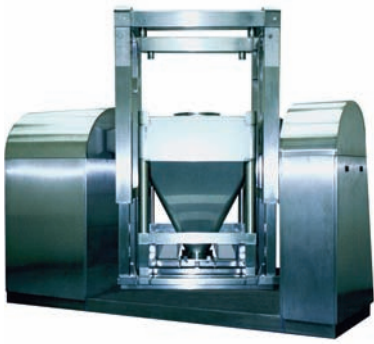

Double Pedestal Blender

Pedestal Blender Range

The Pedestal Blender range allows blending in IBCs upto 3000L capacity. The robust design of the clamping cage securely clamps the IBC at the top and bottom, preventing premature fatigue of the IBCs. The pneumatically operated screw jack clamping system is failsafe, and unlike hydraulic clamping designs, will not loosen its clamp the event of utility failure. The main support pedestal is designed to be housed in a technical area, with optional stainless steel design if the complete machine needs to be located in the clean room production area. The Single Pedestal machines allows blending of "Size 4" IBCs upto 2000L capacity, with a second support pedestal added to the Double Pedestal Blender to allow blending of "Size 5" IBC upto 3000L. The Buck Pedestal Blender is a proven durable design that offers low maintenance and a long working life, the perfect investment for today's pharmaceutical manufacturer.

Dimensions, Weights & Volumes

Model	SP1000	SP1500	SP2000	DP2500	DP3000
Pedestals	One Drive Pedestal and one support Pedestal			One Drive Pedestal	
IBC Size	Size 4	Size 4	Size 4	Size 5	Size 5
IBC Footprint	1125mm x 1325mm			1350mm x 1590mm	
Dimensions	Figure 1			Figure 2	
Dimension A	3330mm	3330mm	3564mm	4835mm	4835mm
Dimension B	2711mm	3184mm	3386mm	4026mm	4026mm
Dimension C	2756mm	3252mm	3443mm	4130mm	4130mm
Dimension D	500mm	500mm	500mm	500mm	500mm
IBC Range (without Swinging Arms)	700L-1000L	900L-1500L	1600L-2000L	2500L	3000L
IBC Range (with Swinging Arms)	-	700L-1500L	700L-2000L	1250L-2500L	1250L-3000L
Maximum working load*	900kg	1250kg	1600kg	2000kg	2500kg
Drive Motor	4.0 Kw	5.5 Kw	7.5 Kw	11 Kw	15 Kw
Control System	Siemens Allen Bradley				
	S7-300 Series PLC, TP177B Colour Touch Screen, Danfoss VLT Series FlexLogix PLC, PanelView Plus 700, Danfoss VLT Series				

* Maximum load calculations are based on weight of the IBC plus a worst case bulk density of 0.8 Kg/L and a 80% product fill ratio.

** Smaller IBCs can be blended by adopting a 'Bottle in Frame' design for the smaller IBC.

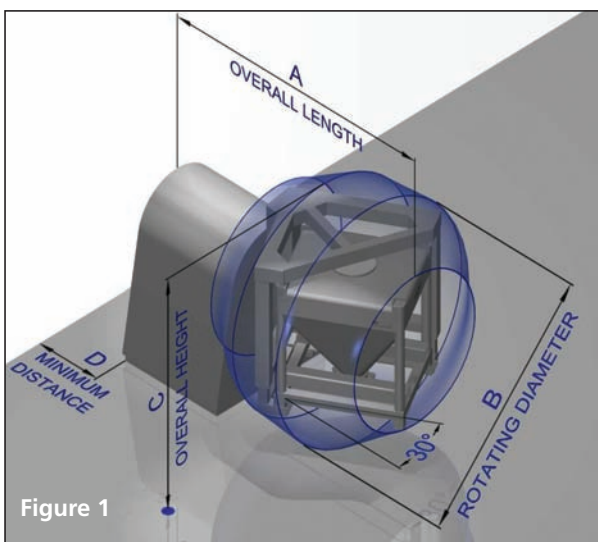

Figure 1

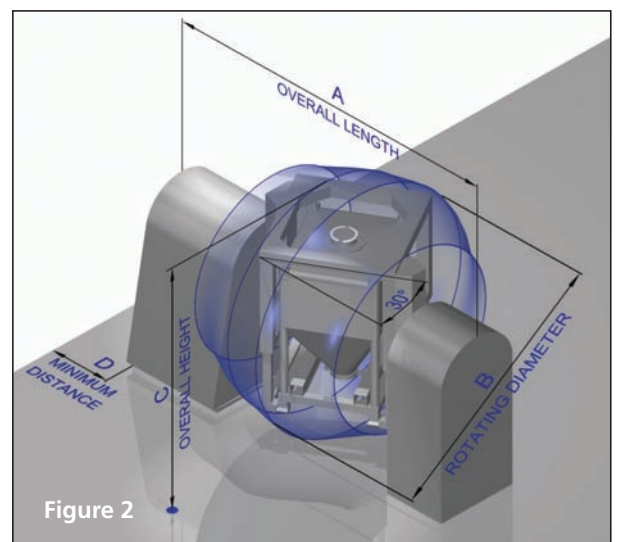

Figure 2

Post Hoist Blender range



PHB1000

The Buck Systems' blender range is extended further with a range of Post Hoist Blenders. All of the features and benefits of the Buck Systems' Blender and Post Hoists are combined into one flexible blending solution.

The Post Hoist Blender provides users with the added benefit of elevating the IBC after blending allowing for direct discharge into a downstream process. IBC to IBC milling and roller compaction are common applications where the Post Hoist Blender provides a combined blending and handling solution.

Modular Lifting Carriage Design

The design of the Post Hoist Blender range is based entirely on the robust and proven post hoist design. The lifting carriage module of the post hoist is replaced with a blending head carriage; the remainder of the column design is the same as the standard post hoist range.

R & D Scale and Pilot Scale Blenders

At the smaller end of the scale, the hoists can be used in R & D and Pilot Scale facilities. The PHB300 and PHB600 allow blending of IBCs up to 300L (Size 1 and 2 IBCs) and 600L (Size 3) respectively. With the addition of a mobile base frame module and mobile safety fence option, the Post Hoist Blender can be a portable unit that can be moved and stored in a safely and effortless manner.

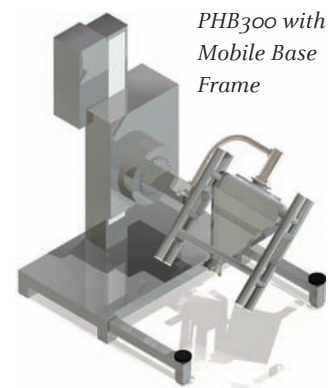

PHB300 with Mobile Base Frame

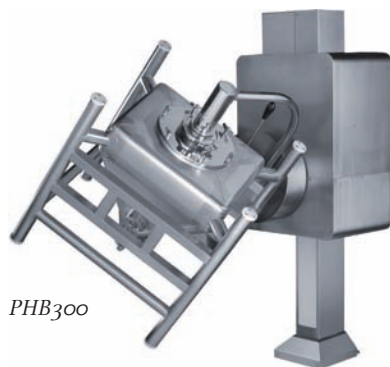

PHB300



PHB1500

Features	PHB300	PHB600	PHB1000	PHB1500
Powered Lift	•	•	•	•
IBC Size	Size 1 / 2	Size 3	Size 4	Size 4
Maximum IBC Size	300L	600L	1000 L	1500 L
Maximum Load (IBC + Product)	300 kg	600 kg	900 kg	1250 kg
Column Height	2 Metres		Room Height	
Fixing	Floor Only		Floor & Ceiling	
Reach	1135mm	1500mm	1500mm	1950mm
Lifting Limit Switches	1 Upper Over Travel / 2 Load Position / Blend Position			
Control System	Siemens S7 300 series PLC with TP177B HMI			
Features	PHB300	PHB600	PHB1000	PHB1500
Additional Height upto 7 Metres	o	o	o	o
Manual Slew	o	o	o	-
Powered Slew	o	o	o	o
Variable Speed Lift	o	o	o	o
Mobile Base Frame	o	o	-	-
External Vibration	o	o	o	o
Butterfly Valve Actuation	o	o	o	o
BuckValve® Control	o	o	o	o
System Integration	o	o	o	o
Allen Bradley Controls	o	o	o	o
Features	PHB300	PHB600	PHB1000	PHB1500
Electrical Power	220-240V 3 Ph 60 Hz or 380-415 V 3 Ph 50 Hz			
Lift Motor Power (Fixed/Variable)	0.25 / 0.55 kW	0.75 / 1.5 kW	0.75 / 2.2 kW	1.1 / 3 kW
Slew Motor	0.12 kW	0.18 kW	0.18 kW	0.18 kW
Blend Motor	1.5 kW	3.0 kW	4.0 kW	7.5 kW
Pneumatics	6 Barg supply pressure			
Pneumatics for Slew Position Lock	3 L/Sec	3 L/Sec	3 L/Sec	-
Pneumatics for External Vibration	10 L/Sec	10 L/Sec	10 L/Sec	10 L/Sec
Pneumatics for Butterfly Valve Actuator	3 L/Sec	3 L/Sec	3 L/Sec	3 L/Sec



SP15

Laboratory Scale

SP15 Laboratory Blender

The Laboratory Blender is a machine specifically designed for small-scale research work with dry powders and granular material. The Blender allows Containers ranging from 3 Litres to 15 Litres to be tumble blended at variable speeds for variable times or revolutions. The unit can easily be manoeuvred within the R & D facility with addition of the mobile trolley.

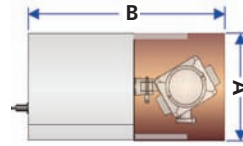

Machine Dimensions

Overall Width A	503mm
Overall Length B	955mm
Overall Height C	545mm



SP15 NIR Laboratory Blender

The SP15 NIR Laboratory Blender is the apparatus that today's pharmaceutical scientist and researcher has been looking for. The SP15 NIR uses Near-Infrared to measure actual powder movement inside the IBC as it is blended. The researcher will be able to monitor ingredient movement on-line, as the blending occurs. This real-time data allows an increased understanding of powder behaviour. Real time blend data reduces the level of sampling and analysing that is needed. The result is faster research times, better understanding of formulation behaviour and a closer control of the blending process.



Plug & Play Container Range

A range of interchangeable Laboratory Containers, from 3L upto 15L volume, is available. The Lab Containers allow complete scale-up to our range of pilot scale and production scale containers. All of the containers feature a removeable Blending Prism™ to allow full evaluation of the improved blending efficiency provided by the Blending Prism™.

Container Capacity	3 Litre	5 Litre	10 Litre	15 Litre
Dimension 'A'	203mm	203mm	243mm	243mm
Dimension 'B'	179mm	179mm	207mm	207mm
Dimension 'C'	172mm	224mm	304mm	400mm
Dimension 'D'	336mm	336mm	356mm	356mm
Dimension 'E'	287mm	287mm	301mm	301mm
Dimension 'F'	220mm	272mm	353mm	448mm

