

Tablet Compression - R150^e



Courtoy™

With **Exchangeable Turret** for maximum flexibility

GEA Pharma Systems supplies advanced technologies for the processing of Active Pharmaceutical Ingredients (API) for the production of oral and parenteral dosage forms.

GEA Pharma Systems strives for *Price/Performance Leadership* providing its customers with highly cost-effective, integrated systems for the pharmaceutical industry. GEA Pharma Systems is dedicated to innovation and thereby providing durable quality through its well-established brands: **Aeromatic-Fielder™** and **Collette™** - batch and continuous granulation, drying, pelletizing and coating; **Buck®** - contained materials handling; **Courtoy™** - tablet compression; and **Lyophil™** - pharmaceutical freeze drying.

GEA Pharma Systems' activities include partnering with customers to develop new products and enhance clinical effectiveness; the supply of R&D-scale and stand-alone production equipment; and the installation of complete integrated production lines.

Specifications

Technical data and layout

TOOLING	EU type D TSM type D	EU type B TSM type B	EU type BB TSM type BB	Special
Number of stations	24	30	36	40
Maximum tablet diameter / length ¹	25,4 mm	16 mm (L = 19 mm)	13 mm (L = 14,3 mm)	8 mm
Punch body diameter	25,4 mm	19 mm	19 mm	16 mm
Outside diameter of the die	38,1 mm	30,16 mm	24 mm	22 mm
Die height	23,81 mm	22,22 mm	22,22 mm	22,22 mm
Maximum fill	20 mm	19 mm	19 mm	16 mm
Maximum precompression force	10 kN under extended dwell-time by air compensator			
Maximum main compression force ²	100 kN			
Variable top punch penetration	1 to 4 mm	1 to 4 mm	1 to 4 mm	1 to 4 mm
Production ³ x 1000	7 to 157 tab/h	11 to 220 tab/h	14 to 264 tab/h	24 to 320 tab/h
Electrical requirements	3phase + PE - 380 V / 400 V / 415 V / 460 V - 50 Hz / 60 Hz - 14 kVA			
Machine height	2000 mm			
Floor space	Basic machine: 1090 x 1050 mm			
Net weight	2500 kg			

¹ The maximum size of the tablet varies with the shape. For odd shapes it is recommended to contact GEA Courtoy.

² The maximum compression force will vary for each application. When the force will be more than 70% of the maximum it is recommended to contact GEA Courtoy.

³ Depending on the application: product, size, shape,...

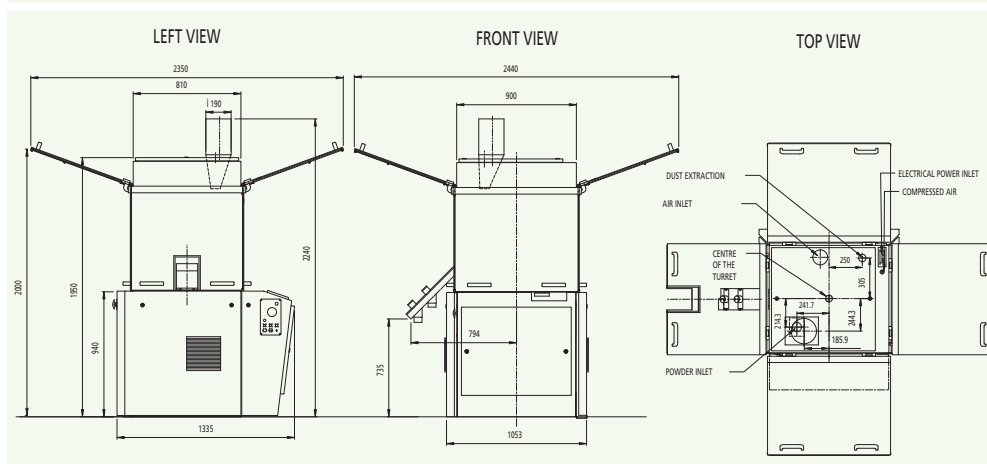

Standard machine features

- Automatic tablet weight control, including rejection of out-of-tolerance tablets
- Automatic tablet sampling and weight correction at adjustable interval
- Double paddle feeder with 2 independent drive motors
- Hard chromium coated die table
- Air compensator system for extended dwell time and maximal punch protection
- Electromagnetic valve in tablet chute for rejection of uncontrolled tablets at start-up
- Electromagnetic valve in tablet chute for automatic or manual tablet sampling
- Automatic & adjustable punch lubrication based on oil mist system
- Identification of bad punch
- Bottom and top punch tightness detectors
- ITS menu for easy and fast sensor off-set & calibration
- Tablet and time counters
- Prewired for connection with automatic tablet checking system (AWS or Combi-Test)
- Prewired for connection of tablet deduster and metal detector

Maintenance and Remote Service & Support

- All electrical components and control system hardware (including PLC, I/O cards and frequency drives) are standard industrial components, sourced from major suppliers worldwide. These components can be sourced locally at low prices and with very short delivery time.
- An optional modem allows Courtoy™ software engineers to perform remote system troubleshooting and software upgrades.



Flexible – Accessible

The Courtoy™ R150° – Maximum flexibility

The R150° has an optional machine-incorporated hoisting arm with separate trolley for easy and rapid turret exchange. The semi-automatic exchange sequence ensures a turret exchange in 20 minutes.

The most flexible way to a quality tablet.

1



2

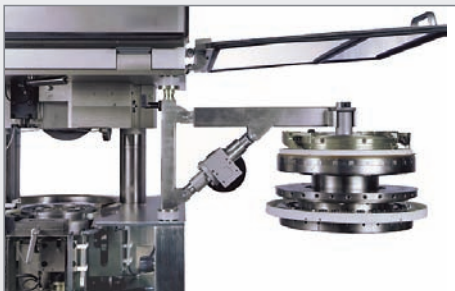

3



The Courtoy™ R150° – Maximum accessibility

Thanks to its four large spring-loaded doors and the elimination of corner pillars or columns, all parts of the compression zone are easily accessible for cleaning and maintenance.

The easiest way to a quality tablet.



Courtoy™ R150^e

Robust – Compact – Fully Automatic – High Yield – Economical

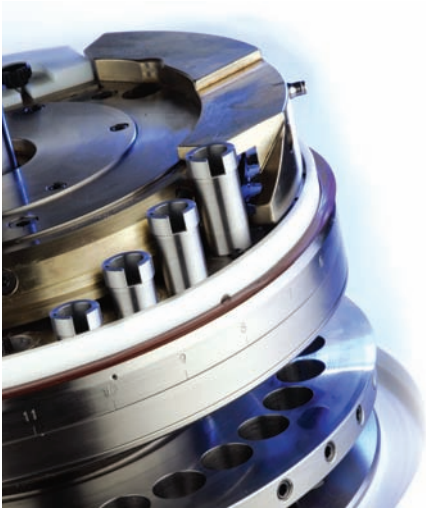

The Courtoy™ R150^e – Extremely robust design

- The machine frame is made of heavy cast iron parts for maximal absorption of vibrations.
- The turret is made of extremely strong forged steel and is entirely nickel coated.
- The die table's working surface has a chrome finish for optimal protection.
- The upper punch guides are fitted with exchangeable guide bushes with key ways for shaped tooling.

The most reliable and robust way to a quality tablet.

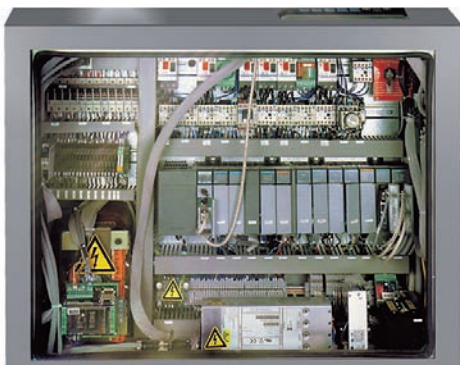

The Courtoy™ R150^e – Compact and mobile design

The electrical cabinet, incorporated in the tablet press body, demands minimal space and makes the Courtoy™ R150^e very easy to install and move around.

The most compact way to a quality tablet.

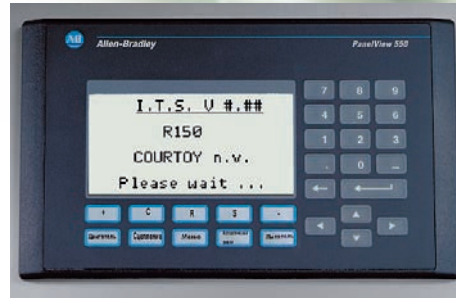

The Courtoy™ R150^e – Fully automatic tablet press

The fully automatic ITS (Integrated Tableting Supervisor) control system with its user-friendly “touch screen”-interface makes the Courtoy™ R150^e easy and secure to use. One simple industrial PLC, using worldwide available, standard components, controls the entire tableting process. The ITS can store up to 90 different recipes and controls any peripheral equipment that is connected to the press. The automatic production control functions guarantee tablet production to the highest quality standards.

The surest way to a quality tablet.



The Courtoy™ R150^e – Maximum yield

The R150^e is available with a special paddle feeder for minimal powder loss and maximal yield.

The most economical way to a quality tablet.

The Courtoy™ R150^e – The most economical Rotary Tablet Press for any type of batch size

The Courtoy™ R150^e includes many standard features, offering outstanding performance in *flexibility, productivity, yield* and *reliability* at an incomparably low price.

The most cost-effective way to a quality tablet.



Central Know-How on a Global Scale

Based on a strong commitment to research and development, pharmaceutical technology centres in Belgium, Denmark, Switzerland, the UK, Singapore, and USA provide global technical support and know-how to the pharmaceutical industry. These centres

of excellence give customers access to a range of test facilities and expert teams with technical and process know-how. Our teams work closely with our customers to optimise processes and evaluate their products, enabling them to achieve their process and production goals.



Contracting Profitable Experience

A world leader in supplying pharmaceutical equipment, GEA Pharma Systems offers manufacturers all over the world the opportunity to enter into a profitable partnership for development and contract. GPS combine advanced in-house technology with a thorough

understanding of the pharmaceutical industry to help customers maximize their development results.



© GEA Pharma Systems 2009. Specifications subject to change without notice. All trademarks recognized. All copyrights reserved. Under no circumstances should this document or any part of it be copied without GEA Courtoy's written consent.



GEA Pharma Systems

GEA Courtoy nv
Bergensesteenweg 186
1500 Halle, Belgium
Tel. +32 2 363 83 00, Fax +32 2 356 05 16
courtoy@geagroup.com